



24-1

Features

Features	Code
Brake Caliper	D
Mounting to the machine parallel to the brake disc	V
Frame size 030	030
Spring activated	F
Hydraulically released	H
Automatic adjustment to counter friction block wear	A
Thruster 230	230
Thruster mounted right or left available	R L
Thickness of brake disc 12,5 mm or 25 mm	12 25

Example for ordering

Brake Caliper DV 030 FHA, thruster 230, thruster mounted right, thickness of brake disc 12,5 mm:

DV 030 FHA - 230 R - 12

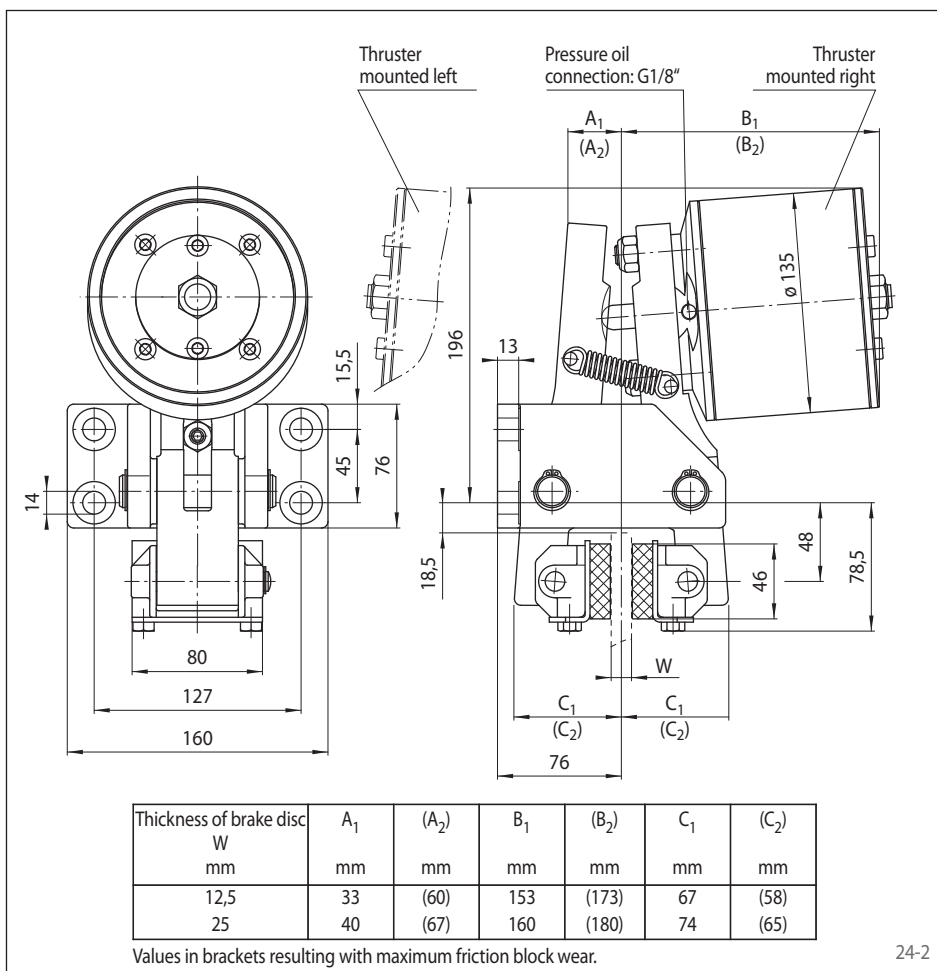

24-2

Technical Data

Brake Caliper DV 030 FHA with thruster 230	
Brake disc diameter [mm]	Braking torque [Nm]
200	620
250	840
300	1100
355	1300
430	1600
520	2000
Clamping force	11000 N
Oil pressure	min. 40 bar max. 100 bar
Oil volume per activation	max. 6 cm ³
Weight	15,3 kg

The braking torques shown in the table are based on a theoretical friction coefficient of 0,4.